

# Flashing Arrow Panel – T/Y 615/815

## All LED 15-Lamp Portable Flashing Arrow Panel

### Product Specifications

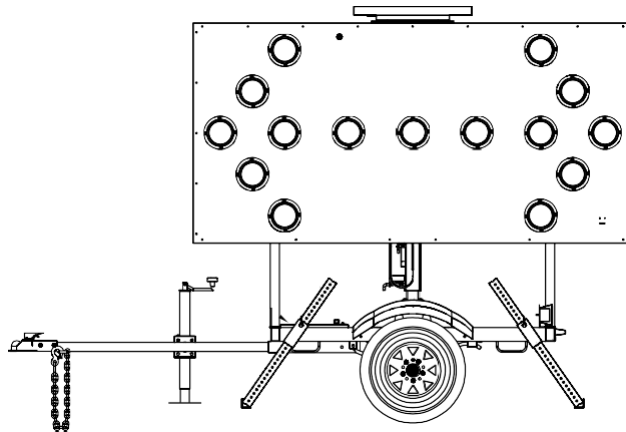

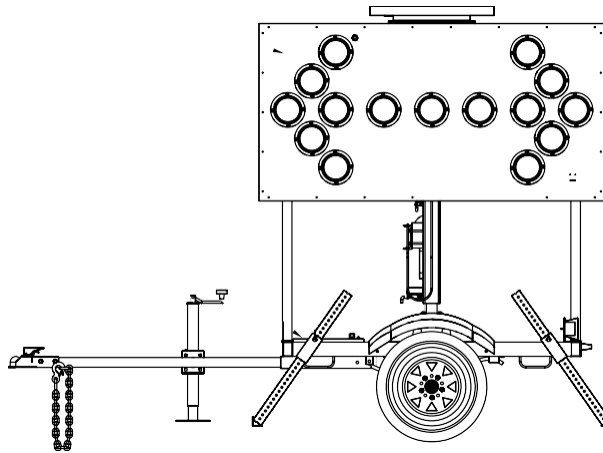

*2755 Bankers Industrial Drive  
Atlanta, GA 30360  
Phone: 770-448-6650  
Fax: 770-448-8970*

## **1. SCOPE**

This specification defines the characteristics and features of an all LED, flashing arrow panel that is capable of MUTCD-designed displays.

- The board may be trailer mounted.
- Additionally, the board may be truck mounted, either at the rear of a flatbed or behind the cab (mid bed) of either a flatbed or pick-up.
- When trailer mounted, the sign system is compatible with a solar charging system in conjunction with an onboard 110 VAC charging capability.
- When truck mounted, the sign system is compatible with charging of the 12 VDC power source battery pack from the vehicle charging system.
- The board system may, as an option, be equipped for wireless operation.
- Meets or exceeds standards set forth in:
  - FHWA
  - MUTCD

## **IMPORTANT FEATURES:**

- 1-mile visibility of display
- Eco-friendly power system featuring high-efficiency solar charging and spill-proof batteries
- Heavy duty all steel welded trailer frame to ensure long life and excellent durability
- Powder-coat and oven-bake paint process to protect it from weather and road hazards

## 2. DISPLAY

### 2.1. Description:

- The display shall consist of an LED lamp matrix comprised of a configuration specific to the board model.
- Each board shall have 15 lamps.

### 2.2. Display Configuration:

- Each lamp shall be 100% solid state with no moving parts or switches, shall be identical to, and mutually interchangeably with, all other lamps.
- No programming modifications shall be required to exchange or replace individual lamps.
- Each lamp shall contain the LED driver circuitry necessary to operate its associated LED's.
- There shall be no separate driver boards between the lamps and the central processing unit (CPU).

### 2.3. LED:

- The lamps shall be comprised of ITE amber (approx. 592 nm) LED providing both daytime and nighttime visibility.
- LED's shall be rated for a 100,000-hour service life and shall have an operating temperature range of - 22 degrees F. to + 165 degrees F.

### 2.4. LED Lamp Shroud:

- Each lamp shall have a hardened plastic shroud nominally 5.5" in diameter and nominally 5.5" long.

### 2.5. Display Power Supply:

- The power supply for the display shall be sufficient to operate the LED lamps for both daylight and nighttime conditions,
- It shall be suitably regulated and temperature stable.
- It shall be fully operational in the temperature range of - 30 degrees F. to + 165 degrees F.

### 2.6. Lamp Wiring:

- The display wiring shall be comprised of positive locking connectors at the CPU and at the individual lamps.
- The wiring shall be comprised of twenty gauge, or larger, individual conductors (no ribbon cables), and shall be configured so as to preclude a malfunctioning lamp from corrupting any other lamp in the display.

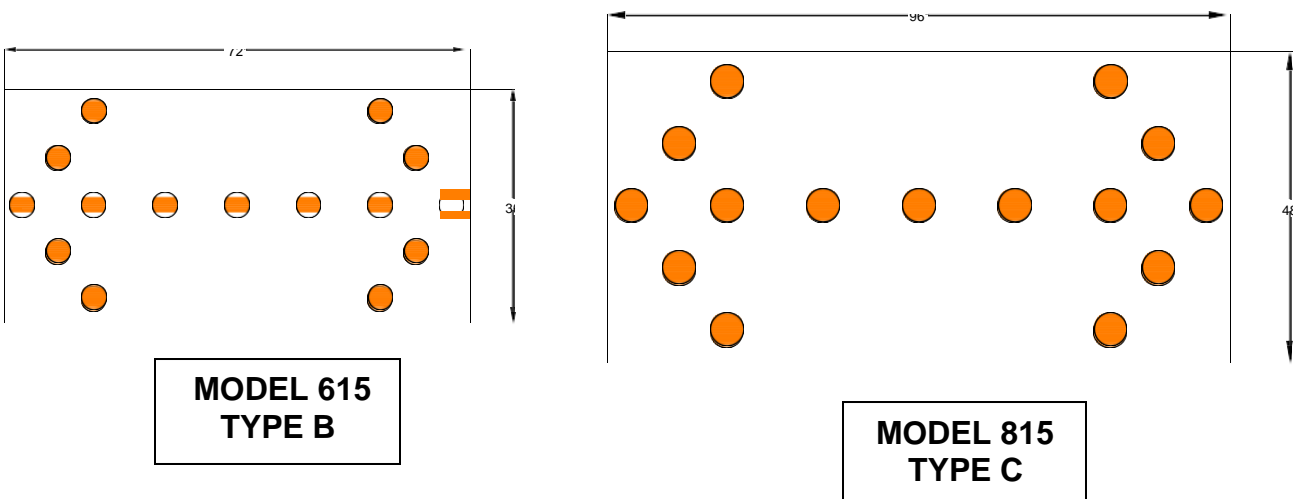



**3. 12 VDC POWER SOURCE**

3.1. Description: The 12 VDC power source for the board system shall be provided by a 12 VDC lead-acid battery bank as follows:

3.1.1. Trailer Mounted System:

- The trailer-mounted system shall be provided with a dedicated battery pack which will yield 30+ days of run time (continuous operation of the arrow panel without solar charging).
  - Battery Type – sealed lead acid 12VDC Bright Way Group
  - 20° Amp Hour Rating - 18 Amp Hours
  - Number of Batteries - 8

3.1.2. Truck Mounted System:

- The truck mounted system shall be powered:
  - Directly from the vehicle electrical system.
  - Or by an optional dedicated battery pack
  - If the dedicated battery pack is connected to the vehicle charging system, it should be isolated by installing a commercially available RV battery isolator.

3.2. Charging: The charging system for the primary power supply shall be as follows:

- The charging system for a trailer mounted board shall be a solar system consisting of a photovoltaic array supplying electrical energy to the batteries through a solar regulator.
- The system shall provide “on demand” charging consistent with battery condition and with the solar luminance at the photovoltaic array.
- The trailer shall be equipped with a 110 VAC receptacle.
- The onboard 110 VAC charging system shall initiate charging automatically when 110 VAC service is connected, and shall be capable of completely charging the battery pack within a 24-hour time period. The actual charging time will vary depending upon conditions and state of charge/discharge of the batteries. Initiation of 110 VAC charging shall completely disconnect the solar charging capability from the charging circuit.

3.2.1. Trailer Mounted System:

FAP Model	Solar Panel Wattage	# of Panels
T625/825	40 Watts	1

3.2.2. Truck Mounted System: The truck-mounted system shall be charged from the vehicle electrical system.



#### **4. CENTRAL PROCESSING UNIT**

##### 4.1. Description:

- The CPU shall consist of a single printed circuit board which shall contain all of the board memory and operating software.
- The CPU shall be a conformal coated 100% solid state unit with no moving parts or switches, shall be operable in 0-95% non-condensing humidity conditions at temperatures from -30 degrees F to +165 degrees F, and shall include provision(s) for protection against damage should the 12 VDC power source be incorrectly connected with the leads reversed.
- The CPU shall be capable of operating the sign system in the event that the wired controller is disconnected.

4.2. CPU Location: The CPU shall be located within the board housing behind the lamps and shall be mounted on the display panel support structure.

4.3. CPU Wiring: For ease of maintenance, the CPU shall contain all of the terminal connectors for the display wiring and the controller cable.

#### **5. DISPLAY CONTROLLER**

##### 5.1. Description:

- The board controller shall utilize industry standard function control commands.
- The board controller shall be nominally 3" x 2" x 1", and shall be permanently affixed for security and ease of use.
- The controller shall be weather-tight, shall be manufactured with conformal-coated circuit boards capable of operation in 0-95% non-condensing humidity conditions, and shall be rated for operation from -30 degrees F to +165 degrees F.

##### 5.2. Location:

###### 5.2.1. Trailer Mounted System:

- On a trailer mounted sign system, the control terminal shall be located on the rear of the display board within a NEMA-style enclosure.
- The enclosure shall be mounted inside the display board, and shall utilize hinges permitting a full 225-degree door swing.
- The enclosure shall have an integrated pad lockable latch and hasp to provide ease of opening and securing of the door.

###### 5.2.2. Truck Mounted System:

- On a truck mounted system, the control terminal can be located in the cab of the vehicle at the customer's convenience and shall be connected to the board display via an electrical umbilical connection at the bottom of the display housing.

5.3. A small hand held key fob controller shall be available for wireless control. The key fob shall be nominally 2 ¼" x 1 ¼" x ½", and shall be electronically synchronized to function with a specific board controller.



## **6. BOARD OPERATING SOFTWARE**

6.1. Description: The sign operating software shall provide for operator interaction with the board system through the trailer-mounted control terminal. Additionally, local access may be achieved utilizing a wireless key fob device.

6.2. Controller: The control terminal shall include:

- on/off power button
- operation mode selector
- current mode display
- display brightness mode selector

6.2.1. Wireless Controller: The optional wireless controller shall be of a key fob design, and shall include:

- operation mode selector
- display brightness mode selector

6.3. Operation Modes: The operation modes shall provide MUTCD configurations for:

- Left/Right Flashing Arrow
- Double Arrow (Merge Right and Left)
- Caution Bar
- Four Corner Beacon Caution

## **7. PANEL CASE**

7.1. Description:

- The panel case shall be of all aluminum construction fabricated utilizing ASTM B 209 6063-T5 extrusions and 3003-H14 sheet material.
- Case Dimensions for the Type C 815 – 48” High X 96” Wide
- Case Dimensions for the Type B 615 – 36” High X 72” Wide
- The case shall be nominally 3” in thickness and shall be painted flat black on all interior and exterior surfaces.

7.2. Board Case Housing: The sign case shall contain the display lamps, the display power supply, wiring harnesses, and the photocell.

## **8. SIGN SUPPORT**

8.1. Description: The configuration of the actual support structure will be dependently variable as the type of vehicle upon which the board is transported and/or displayed varies.

8.2. Vehicle Type:

- The sign may be transported and displayed on a dedicated trailer that accommodates the 12 VDC power source batteries and the combination of solar and 110 VAC charging systems.
- Alternatively, the board may be transported and/or displayed on a pick-up or flatbed truck with one of several support structures



8.2.1. Trailer Mounted:

- If trailer mounted, the raising and lowering mechanism shall be of a hand crank winch-and-pulley design.
- The solar array shall be mounted on a level mechanism such that the array is maintained in a nominally horizontal plane.
- The pivot mechanism shall be constructed such that a single operator can deploy the display and the solar array simultaneously.
- The crank design shall be a powder coated brake winch rated for 800 lbs., shall meet ASAE Safety Standard S361.3, and shall use a 4.4:1 gear advantage.
- The height of the trailer mounted board in the transport mode shall be 97" to the top of the solar array, and in the display mode, 132" to the top of the solar array.

8.2.2. Truck Mounted:

- The board may be mounted permanently or semi-permanently on a truck by bolting the sign support structure to the bed floor or walls.
- The board may also be mounted temporarily utilizing askid mount that fits in the bed of the vehicle.
- With any mounting configuration, it is recommended that the support structure accommodate tilting the board to a horizontal position for transporting and to a vertical, or nearly vertical, position for display.

**9. TRANSPORT VEHICLE**

9.1. Trailer: For trailer-mounted boards, the trailer shall meet the following requirements:

9.1.1. Description:

- The trailer shall be 113.3" in length with the retractable and removable tongue in place and 64.2" in width.
- It shall be constructed of 3" x 2" steel tube (ASTM A 500 Grade B) with 1/8" wall thickness and shall be welded in accordance with applicable American Welding Society (AWS) standards.
- The trailer shall have a lockable, weatherproof enclosure housing the controller, and a battery box whose lid is secured by tamper-resistant Torx bolts for the 12 VDC power source batteries.

9.1.2. Rating:

- The axle shall be rated for 1900 pounds, the springs for 1900 pounds each set,
- The wheels shall be 15" steel with 5 lugs bolts per wheel and fitted with 175-80-13 C rated tires.
- The retractable tongue shall be fitted with a 2" ball coupler rated for 5000 pounds.
- Standard axle is leaf spring, customer may upgrade to a torsion suspension system if required.

9.1.3. Removable/Retractable Tongue:

- The retractable tongue shall be fabricated from 2" X 2" steel tube (ASTM A 500 Grade B) with 1/8" wall thickness, shall be affixed to the body of the trailer, and shall have safety chains attached.
- The lighting lead shall be affixed permanently to the tongue and shall separate from the trailer wiring harness at a plug connector when the tongue is retracted.
- The tongue shall have a 2-ton capacity top-wind leveling jack affixed to it.

9.1.4 Stabilizing Legs:

- The trailer chassis shall have at each corner a Telespar-style stabilizing leg affixed in such a manner that the legs may be readily retracted and locked in position for traveling without necessitating the use of any tools.



- The trailer and sign assembly, when stationary and supported properly with the leveling jacks shall withstand AASHTO rated 100 MPH wind gusts.

9.2. Trucks: The board system may be mounted on a variety of vehicles ranging from full size pick-ups to flatbeds, long line strippers, etc. Mounting specifications will vary with the transport vehicle.

## **10. OPTIONS**

10.1 Description: The FAP may be provided with additional equipment for ease of operation.

10.2 Expanded Power Configurations: The FAP models can be outfitted with larger capacity solar panel for extended run time.

10.3 Wireless Operation: The FAP display can be operated by a wireless handheld controller or keyfob.

10.4 Trailer Paint: The FAP trailer can be painted a variety of colors.

10.5 Miscellaneous: American Signal is able to meet the user's needs for additional hardware items. We are able to provide any hitch type (Ball, Pintle or Lunette Eye, Bulldog, Adjusting Height, etc...), axle type, lift requirements, color specifications, alarms, etc.

***Note of Application:*** This specification is widely applicable to catalog items AMS30115301, AMS30115380, AMS30115401, AMS30115480. Catalog designations and this specification are subject to change without notice.